

## Screw-cap tester

---

### DTX2 Series

#### Torque tester of screw-caps with easy data processing



#### [Applications]

- Measure the torque of screw caps of cosmetics, foods or drinks.

#### [Features]

- Less shakiness of the table unit.
- Weight of table unit and vertical force are kept by 2 ball bearings.
- Easy to clamp the sample by 4 clamping mouth-pieces.
- Digital display shows CW/CCW torque and peak torque.
- Comparator function which can program Hi/Lo set point.
- Memory stores up to 1000 measurement.
- Various outputs RS-232C for PC, Analog and Mitutoyo Digimatic.
- Selectable three units (N·m/Kgf·m/lb·in or N·cm/Kgf·cm/lb·in)
- Two models ( battery use or AC power use) are available

## [Models]

There are 6 ranges for each series as the followings

Model		Capacity	Display	Resolution
DTX2-2-A	DTX2-2-B	2N·m	2.000N·m	0.001N·m
DTX2-5-A	DTX2-5-B	5N·m	5.000N·m	0.001N·m
DTX2-10-A	DTX2-10-B	10N·m	10.00N·m	0.01N·m
DTX2-200Nc-A	DTX2-200Nc-B	200N·cm	200.0N·cm	0.1N·cm
DTX2-500Nc-A	DTX2-500Nc-B	500N·cm	500.0N·cm	0.1N·cm
DTX2-1000Nc-A	DTX2-1000Nc-B	1000N·cm	1000N·cm	1N·cm

Difference between models followed by “-A” and models followed by “-B”

Model	Source of Power
DTX2-[range]-A	Mains AC100V~240V
DTX2-[range]-B	NiMH rechargeable batteries or AC adapter

## [Optional Accessories]

Analog cable CB-201 Connects this unit to analog instruments	Pen recorder SS-100F-MM Plots graphic chart by analog output from this unit
RS232C cable CB-204 Connects this unit to computer	Software ZLINK2E Plots chart and records measurement via RS-232C output form this unit
Digimatic cable CB-304 Connect this unit to Mitutoyo Digimatic mini-processor.	Digimatic mini-processor DP-1VR You can print out measurement, and also take simple statistics.

## [Specifications]

Model	DTX2-A Series	DTX2-B Series
Measuring units	N·m/kg·m/lb·in or N·cm/kg·cm/lb·in	
Display	4 digit LCD Unit-Mode-Overload LED-Comparator LED	
Sampling rate	1000 times/sec.	
Display update	10 times/sec.	
Over torque capacity	150% of rated capacity LED flashes and buzzes beyond 110% of capacity	
Diameter of sample	20 mm to 180 mm dia.	
A/D converter	24 bits delta sigma	
Processor	8 bits 1 chip micro processor	
Accuracy	+/- 0.5 % of rated capacity	
Battery use		Approx. 8 hours 10 hours for charging
Temperature of use	0 – 40 degree Celsius	
Power source	100 to 240 VAC	NiMH rechargeable battery AC adapter -1
Dimensions	See next page ...	
Weight	Approx. 4.5 kg	
Outputs	RS-232C Mitutoyo Digimatic Analog voltage +/-2V	
	Comparator signal (+NG, OK -NG) Open collector max. 30 VDC 10 mA	
	Over torque warning signal (OVL) Open collector max. 30 VDC 10 mA	
Inputs	Close contact Display hold, zero, peak/track select	
Peak mode	“And” mode (peak of CW and CCW) or “Or” mode (peak of CW or CCW)	
Comparator	Programmable hi/low set points with color coded indicators and output	
Memory	Up to 1000 data can be stored	
Alarm	Output, buzzing and LED flashing for over torque warning	
	Buzzing at the value of comparator +NG	
Others	Auto zeroing (selectable between 1.0 and 25.5)	
	Dumping (selectable 7 levels)	
Auto-power-off	Disable, 5, 10, 30, 60 minutes selectable	

-1 Since commercial power supply voltage varies in the area where the gauge is used, three types (100V, 120V, 230V) of voltage adapters are available. Please specify the confirmed voltage for the commercial power supply when you order.

## [Dimensions]

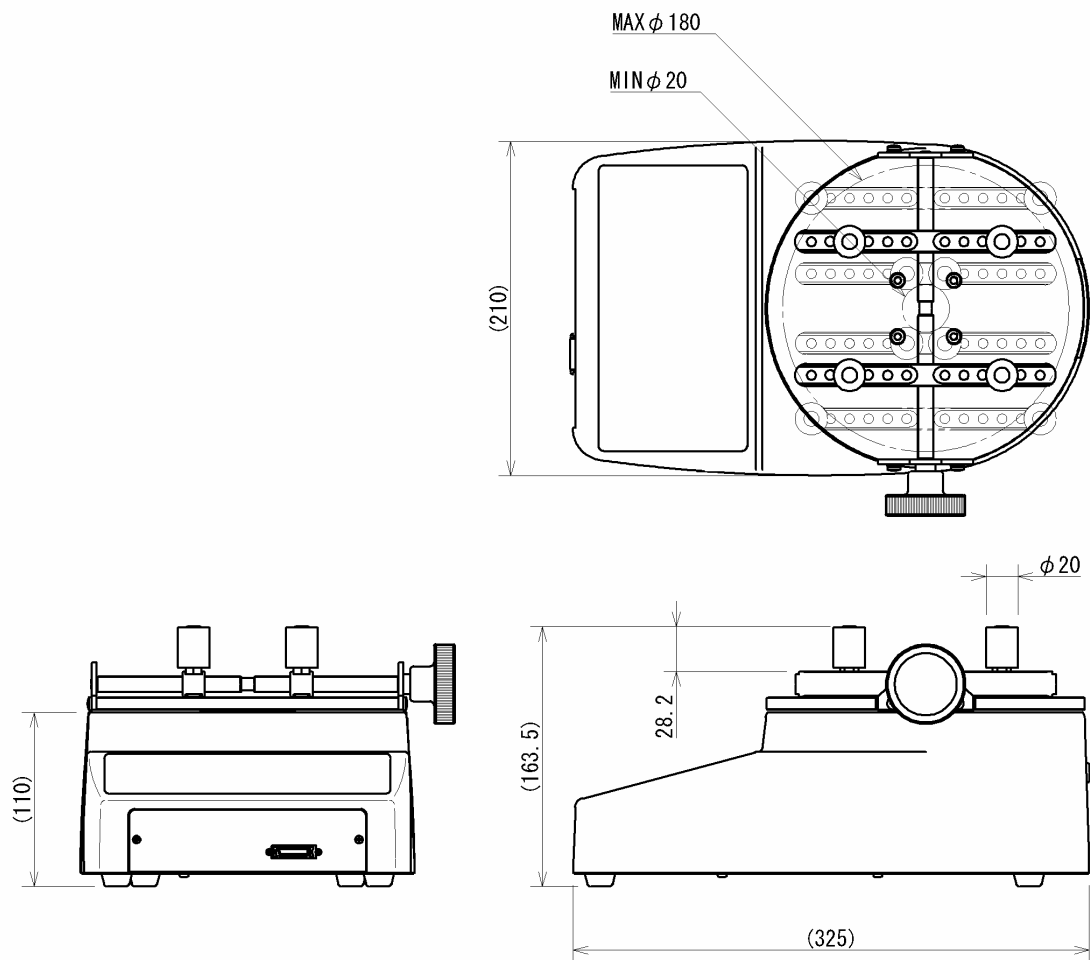

## [Notes]

- Do not apply excess torque, force, or impact on regardless to the power is on/off.
- Do not use the instrument under the condition of the rapid temperature changes, high temperature, high humidity, near water and dusty place.
- All information is subject to change without prior notice.